

Smarter Control Design

Make It Robust. Optimize Under Constraints. Let It Adapt.

Gernot Schraberger

April 21, 2026

Agenda

- Plant Modeling & Parameter Calibration
- Linear Control Design for Robustness
- Gain Scheduling Control
- Model Predictive Control
- Adaptive Control

What should be controlled?

Describing the plant

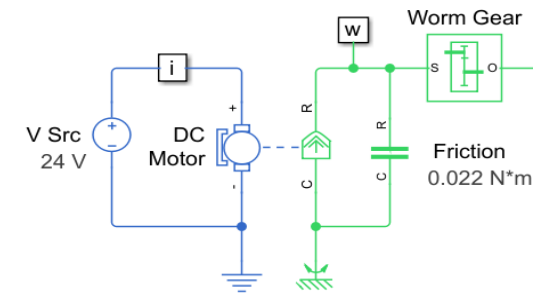

$$\frac{s^2 + 3s}{s^4 + 6s^3 + 13s^2 + 18s + 4}$$

$$\frac{s(s+3)}{(s+3.732)(s+0.2679)(s^2 + 2s + 4)}$$

Plant model as starting point for control design

Frequency Domain

Time Domain

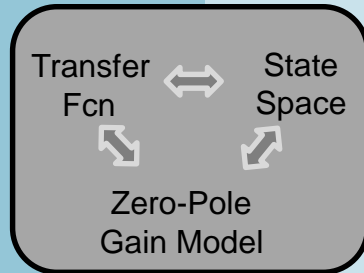

linear ODEs

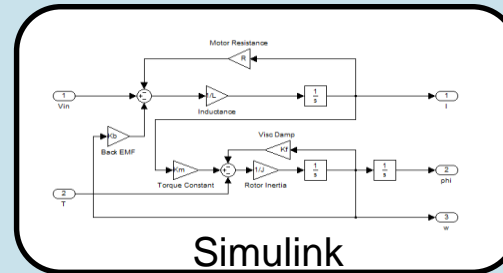

non-linear ODEs

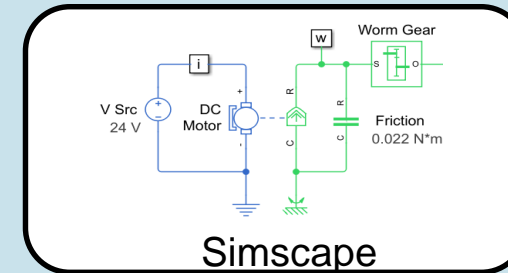

non-linear DAE (Physical System)

First Principles

Frequency Response Data

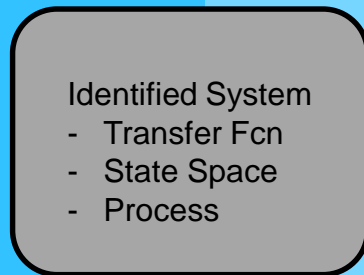

linear ODEs

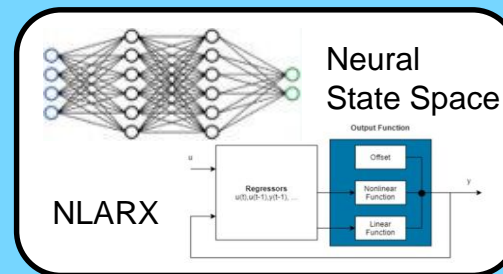

non-linear ODEs

Data Driven Black Box Models

- Use model type that is best fitting
- The more pre-knowledge available, the better

Estimate Plant Parameters Using Measured Data

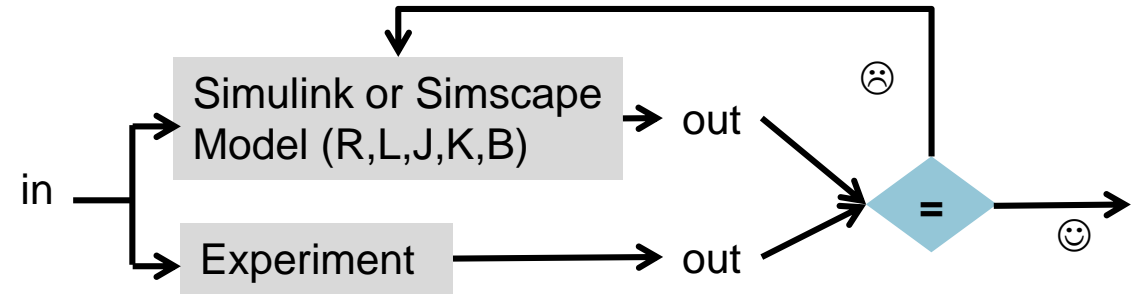
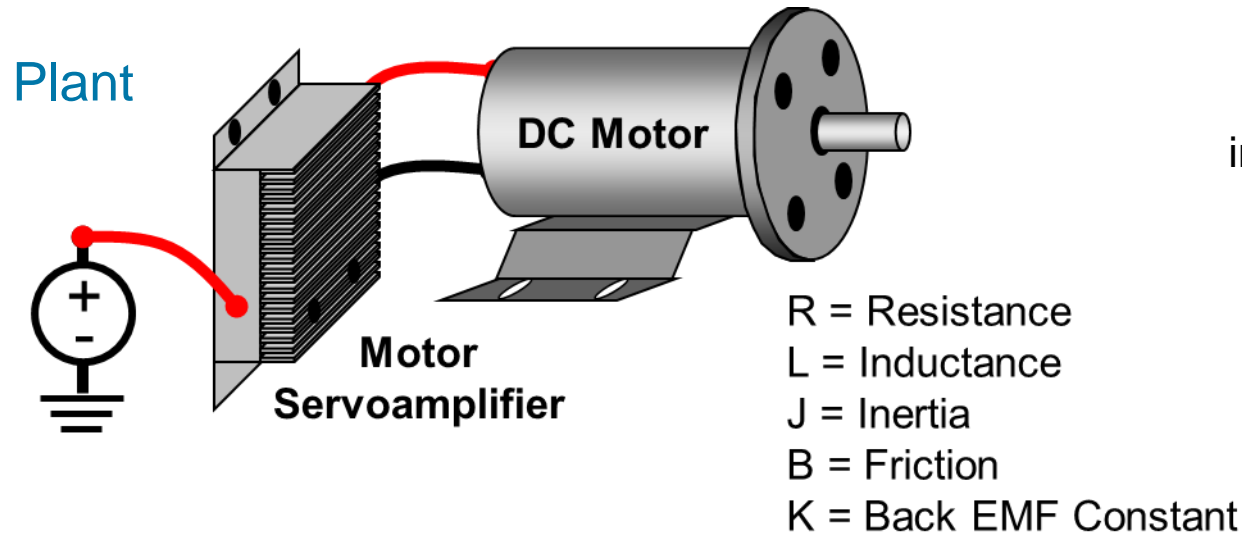

Workflow

- First principles model structure known
- Exact parameters unknown
- Automatically tune model parameters to calibrate model

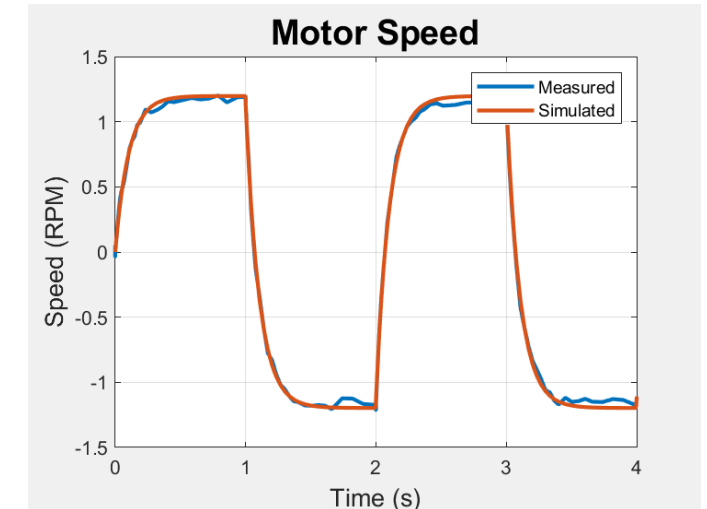

R	L	J	K	B
4.03	1e-4	0.11	0.45	1.07

Linear Control Design

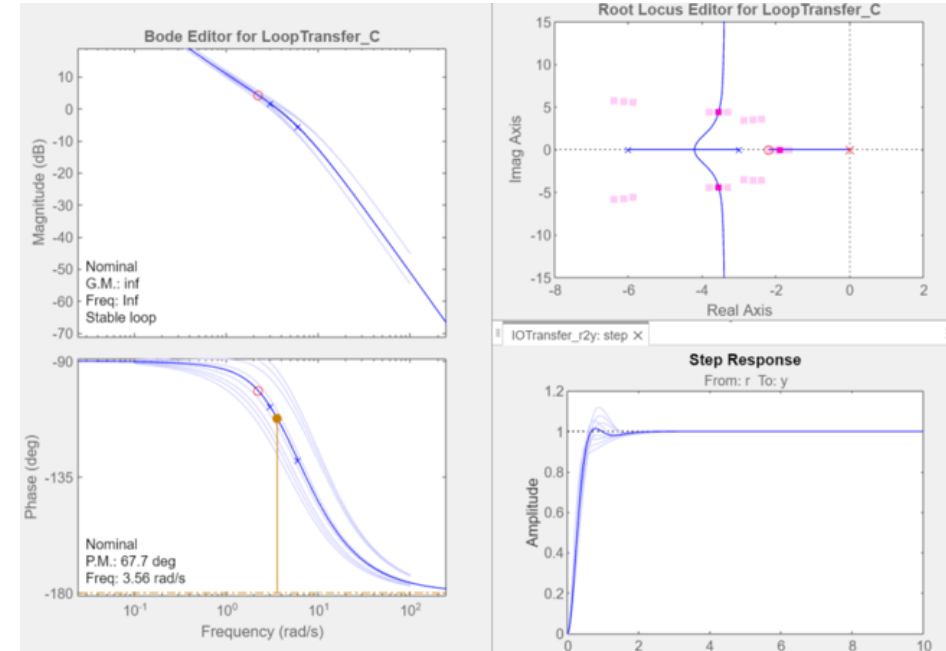

Control Design Workflow (Classical Methods)

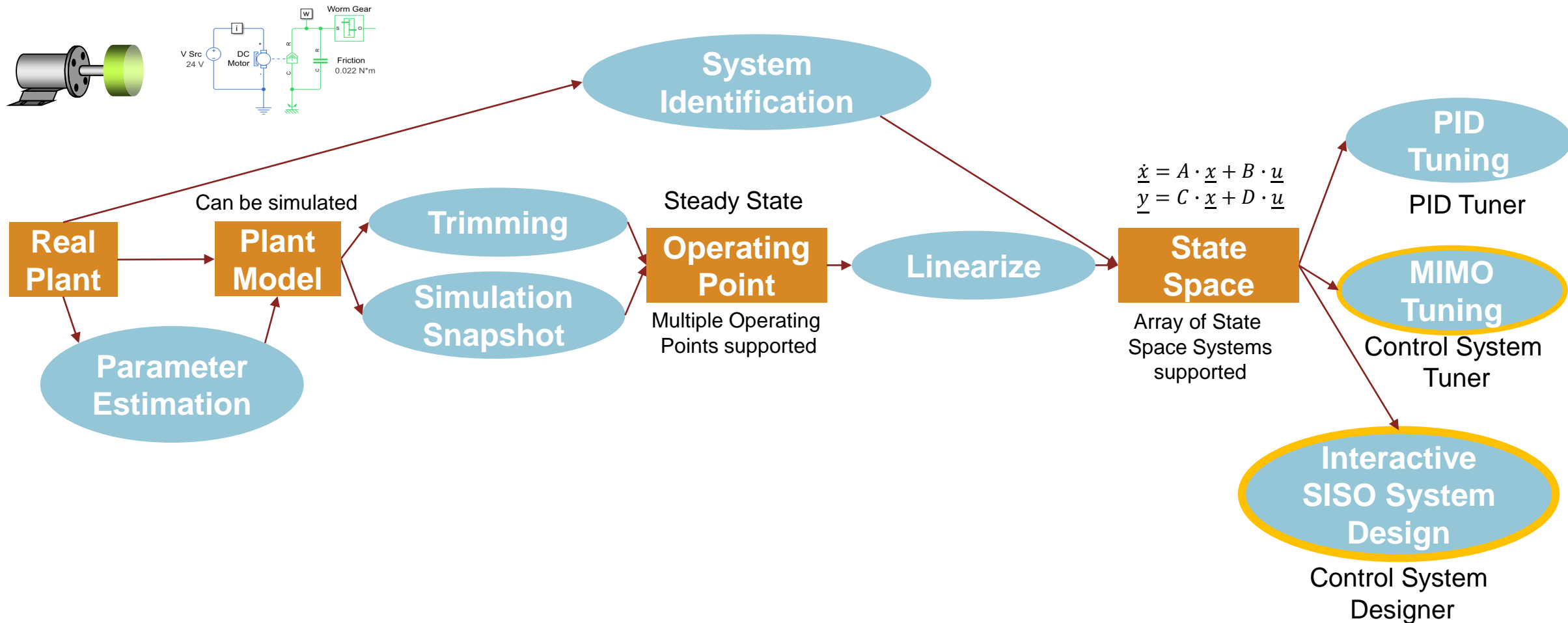

Design a Linear Controller Interactively

Control System Designer App

- Supports SISO systems
- Used to
 - find architecture of controller
 - design for steady state accuracy
- Interactive plots
 - Bode (open/closed loop)
 - Root Locus
- Adjust gain
- Add poles, integrators, zeros
- See response for uncertain parameters or for different operating points

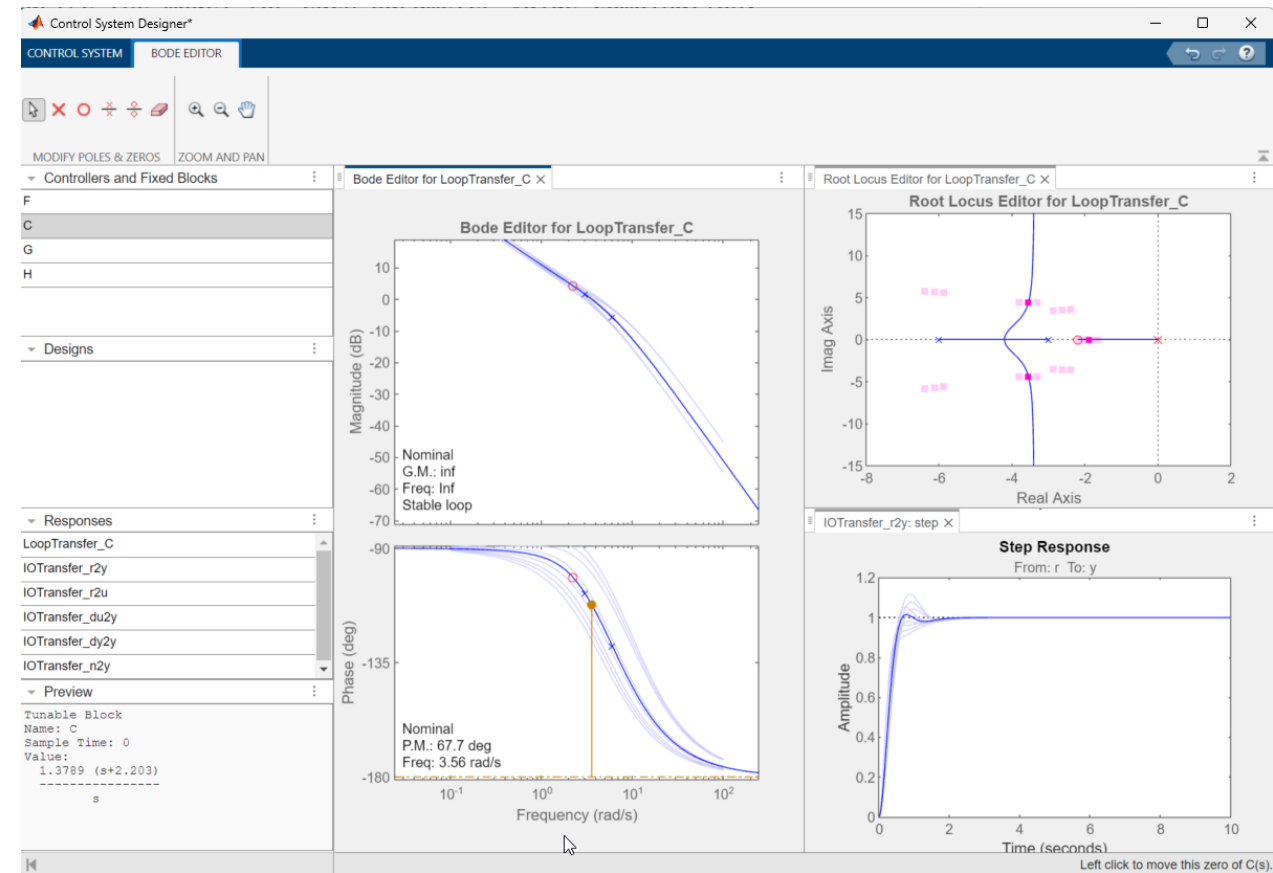

Controller Tuning for MIMO Systems

Control System Tuner App

- Supports
 - any linear control model (incl. observers, filters etc.)
 - arrays of linearized plant models (robustness)
 - MIMO systems
 - Variety of tuning goals in time in frequency domain

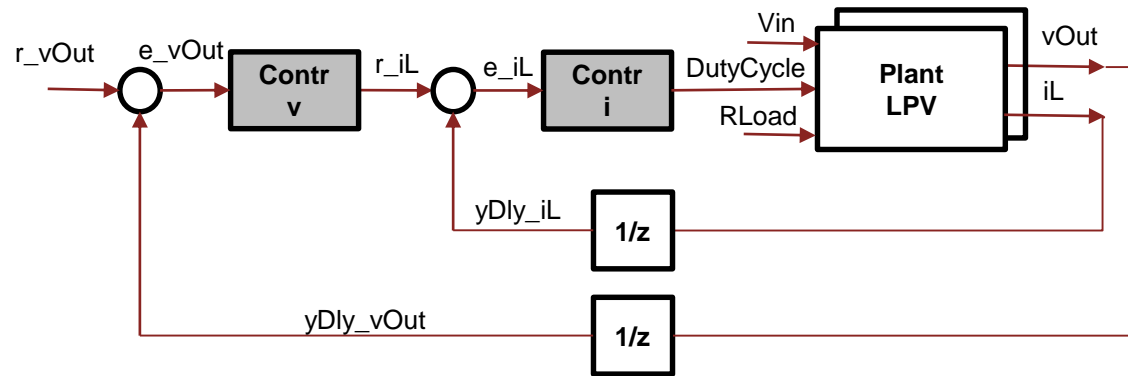

Tuning Goals

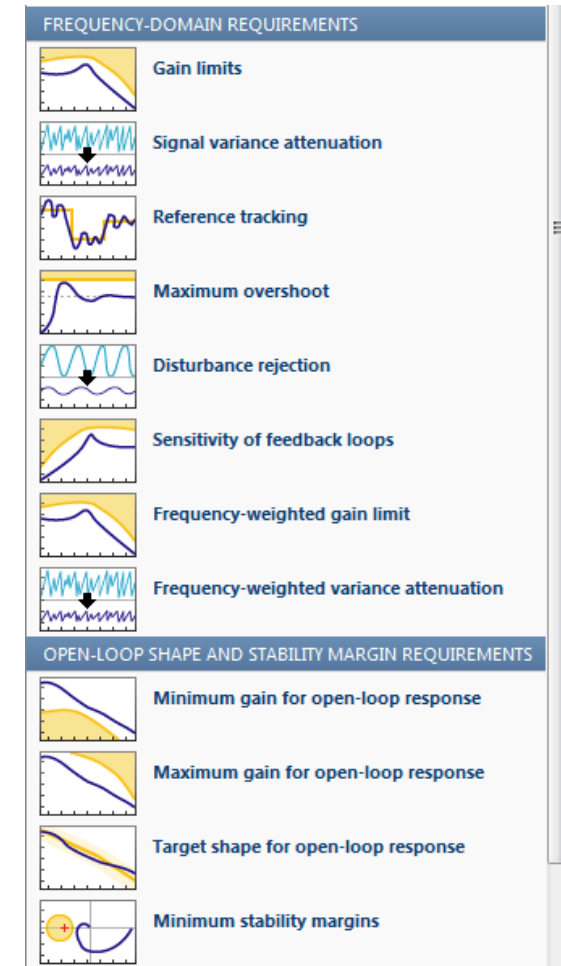

Robust Control Design with Control System Tuner

Conclusion

- Multiple plant linearizations used in parallel
 - Robust design
 - Less validation efforts
 - Observe effects of controller for all operating conditions or uncertainty variants at once

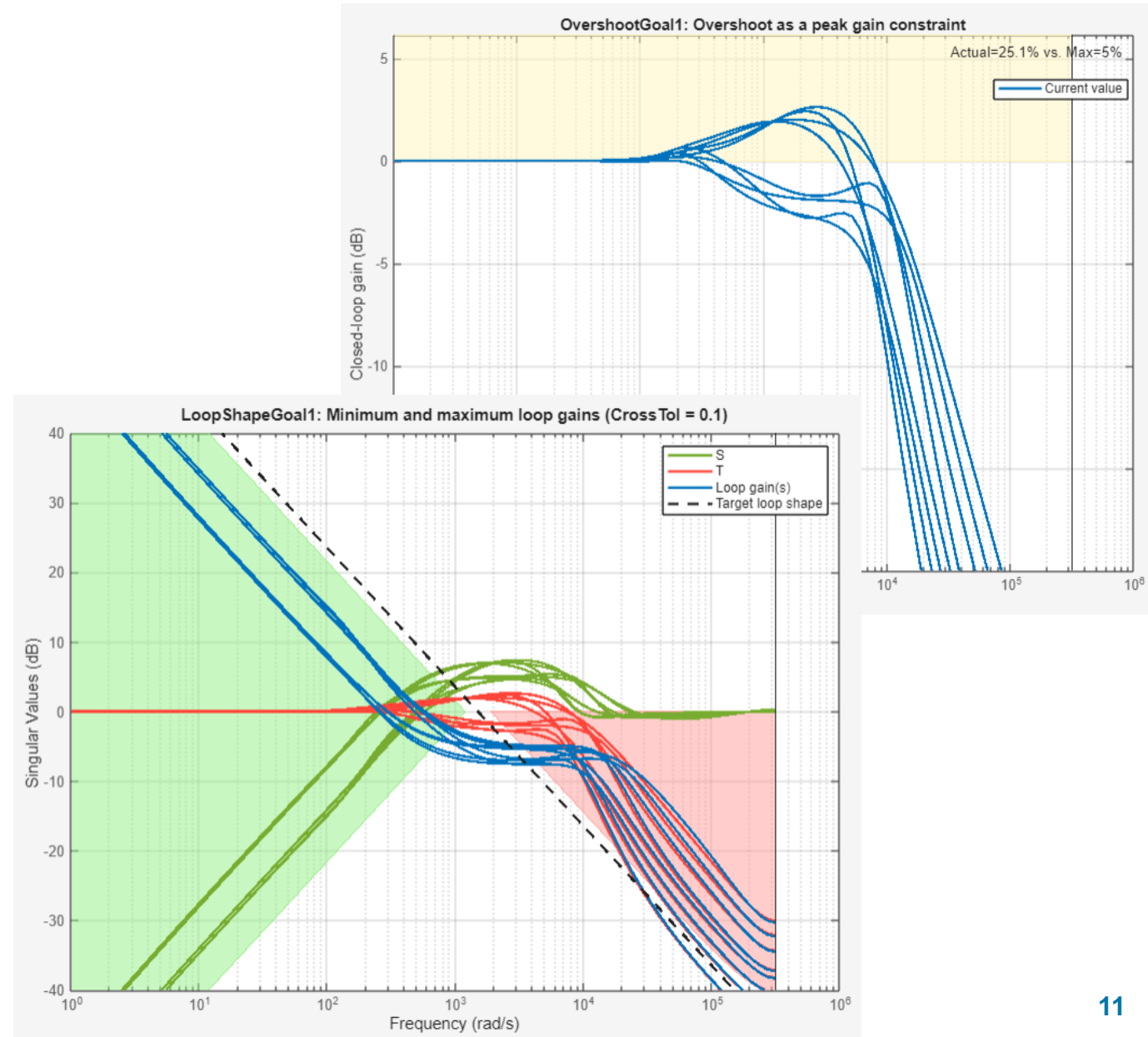

A-priori Knowledge used for Parameters Adaption

Gain Scheduling Controller

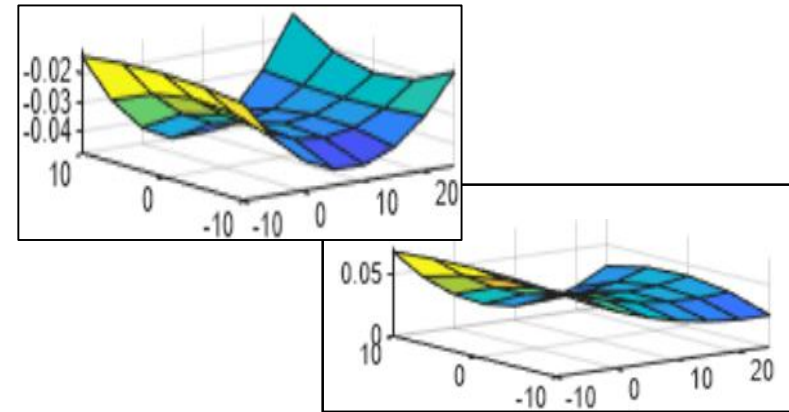

Gain Scheduling Controller

- Non-linear plant with changing operating conditions
- Not a single robust controller but one that adapts to different operating conditions
- Transition between corner cases should typically be smooth

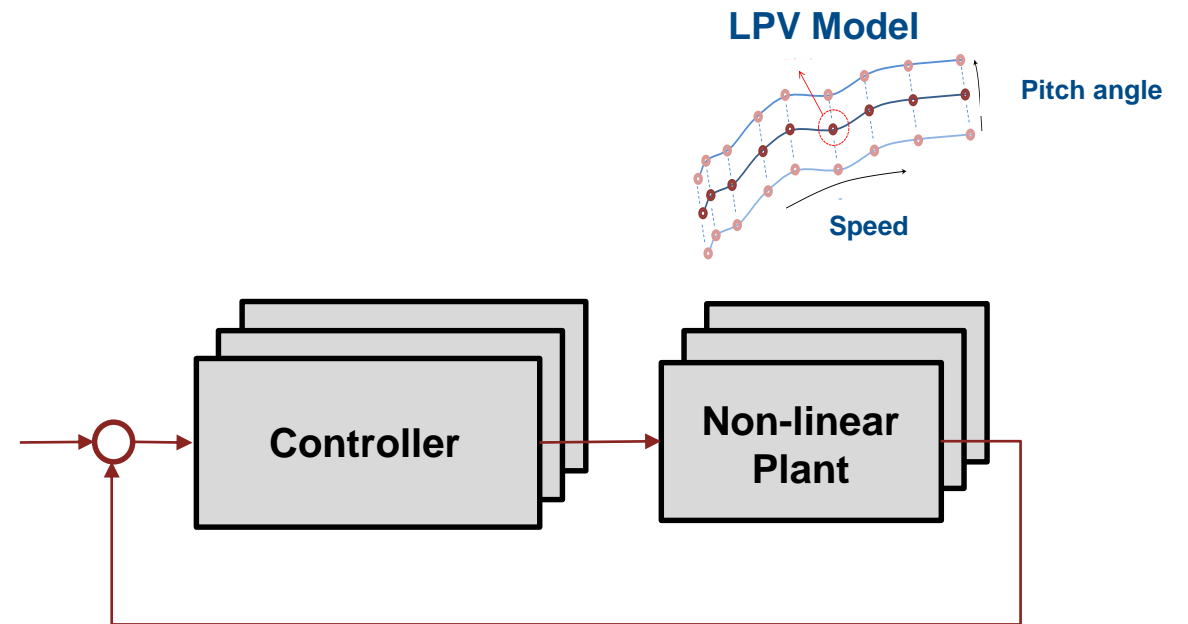
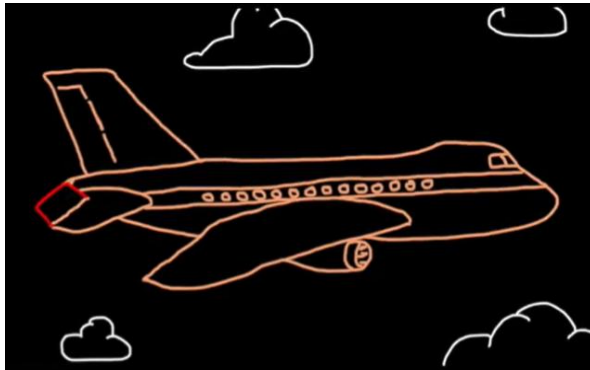

Gain Scheduling Controller

How to design it?

- Array of linearized plant model descriptions for different operating conditions
- Tune the gains (performance & stability) of any linear controller
 - Tracking behavior
 - Margins
 - etc.
- Implementation of Scheduling as polynomial
- Assess controller performance in
 - Corner cases
 - Transitions

```
TuningGrid = struct('Cr',CrEQ);
ShapeFcn = @(Cr) [Cr , Cr^2];
```

```
Kp = tunableSurface('Kp', 0, TuningGrid, ShapeFcn);
Ki = tunableSurface('Ki', -2, TuningGrid, ShapeFcn);
```

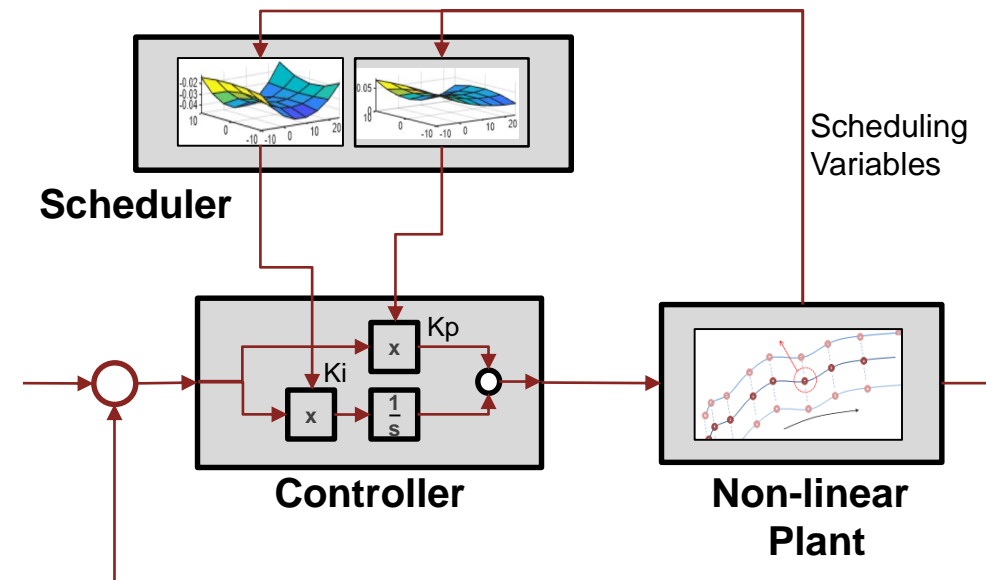

```
ST = systune(ST0, [R1 R2 R3], R4);
```

Optimize Under Constraints

Model Predictive Control

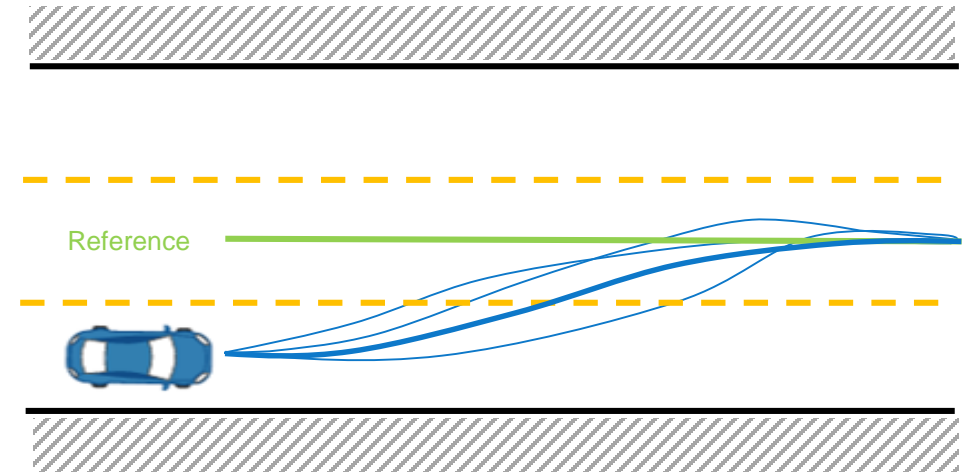

Optimize Under Constraints

Model Predictive Control (MPC)

- Example: Maneuver the car along the optimal path taking care of reference path and road constraints / obstacles

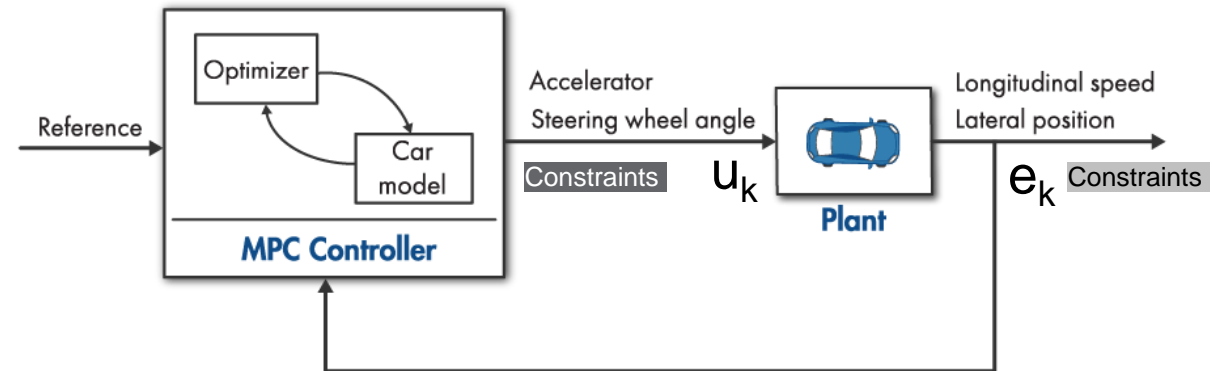
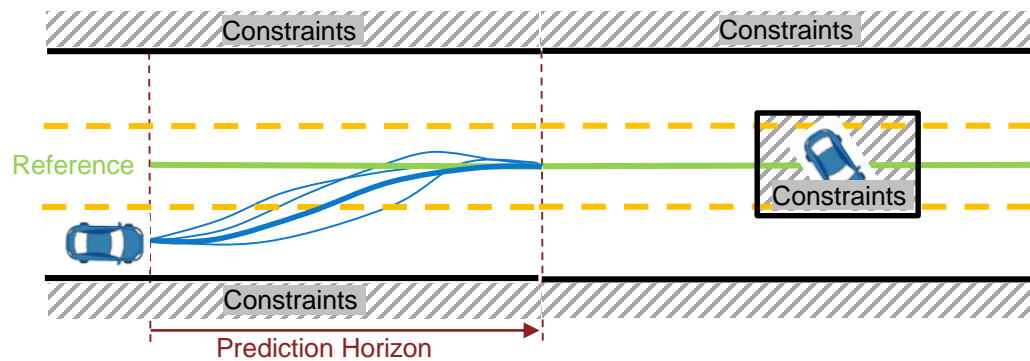

$$\text{Cost function } J = \sum_{i=1}^p w_e e_{k+i}^2 + \sum_{i=0}^{p-1} w_{\Delta u} \Delta u_{k+i}^2$$

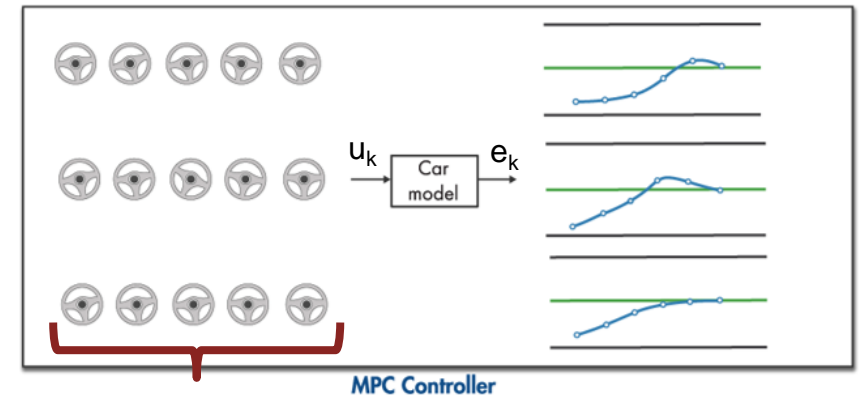

Design Variables for optimization over prediction horizon

Benefits of MPC

- MPC finds **optimal path** with minimal costs
 - By optimizing all controller output variables over prediction horizon
- Constraints are taken into account
 - at controller outputs (similar like saturation & anti-windup at PID)
 - at plant outputs (**no equivalent concept with classical control**)
 - Can be used for **path planning** (even for very complex ones like parking maneuvers)
- Supports MIMO systems

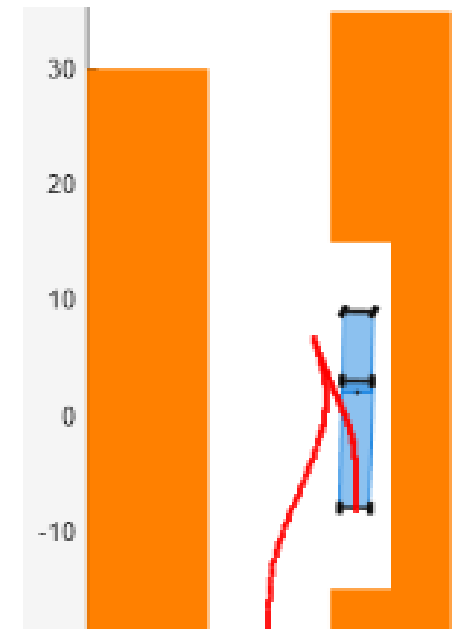

Car x/y-positions
& orientation



Steering



Throttle / Brake

Supported MPC types

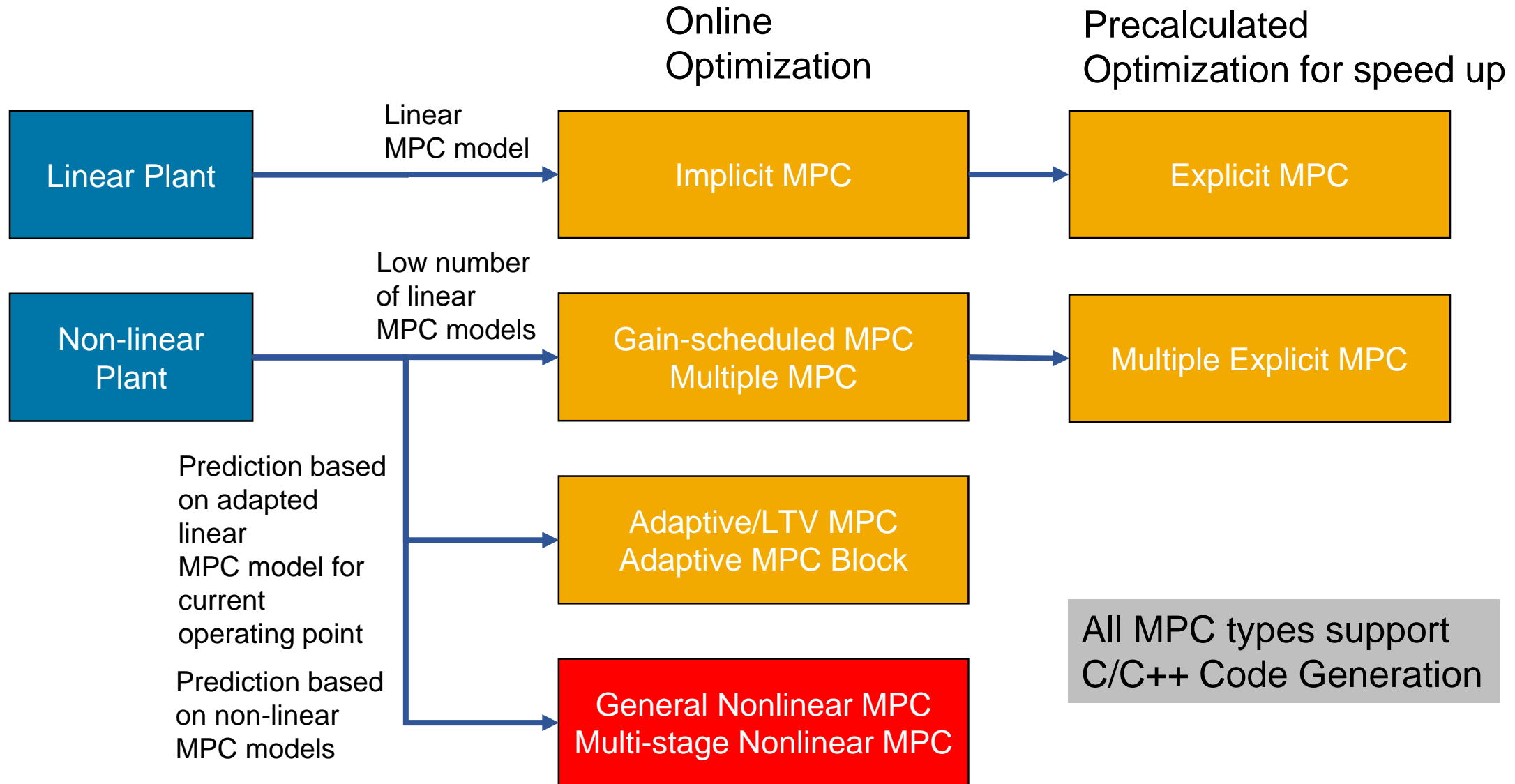

Let it adapt !

Adaptive Controllers

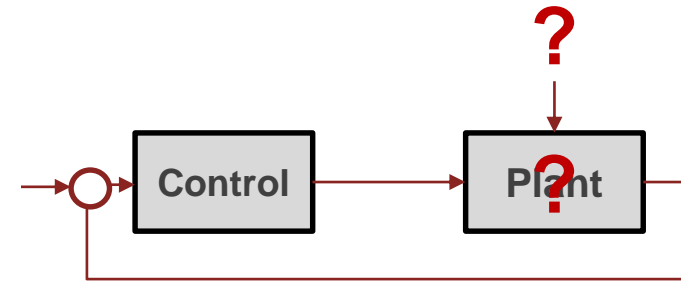

Adaptive Control

What is it about?

- Controller constantly optimizes control parameters to adapt to variations
- When the model is uncertain and the environment changes
 - Unknow or uncertain dynamics (e.g. aging effects, varying environment)
 - Exposed to disturbances



Chowdhary G., Johnson E., Chandramohan R., Kimbrell M. S., Calise A., [Autonomous Guidance and Control of Airplanes under Actuator Failures and Severe Structural Damage](#), AIAA Journal of Guidance Control and Dynamics, Vol. 36, No. 4, pp. 1093-1104, 2013

Controller Methods

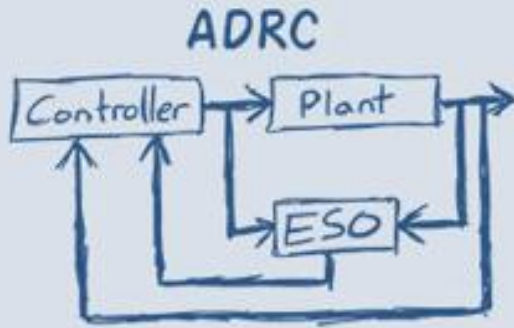

- Extended State Observer estimates disturbance
- Disturbance is assumed to be slow
- Disturbance is compensated so that classical control can be applied
- Only for 1st or 2nd order systems
- Needs a critical gain value from plant
- Motor-, Inverter-, Temp-Control

- Make plant follow a given linear reference model
- Using pole placement to match the poles with reference system
- Applying disturbance model as weighted sum of state functions
- MIMO systems supported

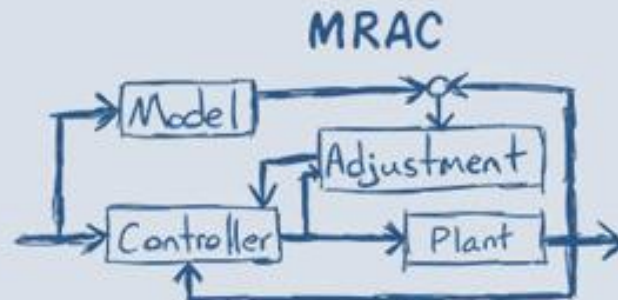
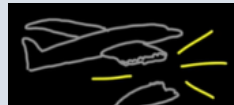

- Model-free online optimization
- Injection of sinusoidal modulation signal to detect performance changes and to adapt controller
- Max. Power Point Tracking

EXTREMUM SEEKING

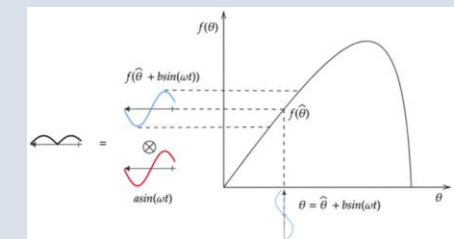
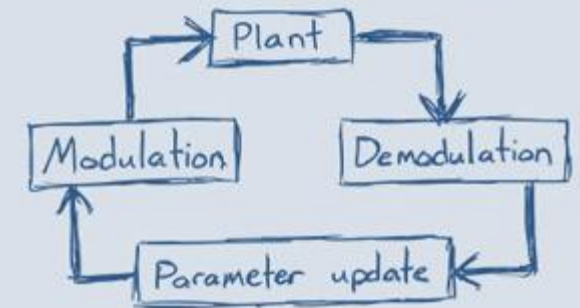

Model Reference Adaptive Control

How does it work?

Controlled model adapts to a given reference linear model

- Nominal controlled system(reference model) is linear
- Using pole placement (K_r, K_x) to match the poles
- Applying disturbance model as weighted sum of
 - States
 - Radial Basis Functions
 - Single hidden layer neural network
 - Custom functions (externally supplied)
- Update with specific learning rates $\Gamma_x, \Gamma_r, \Gamma_w$

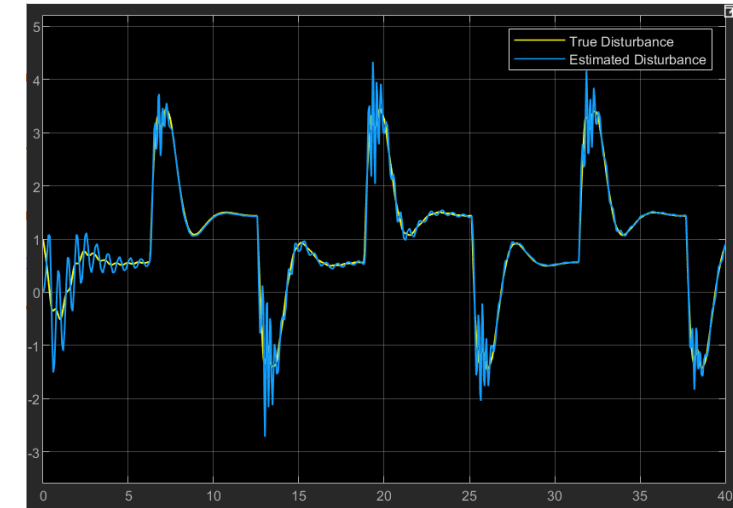

Custom fcn used for disturbance model

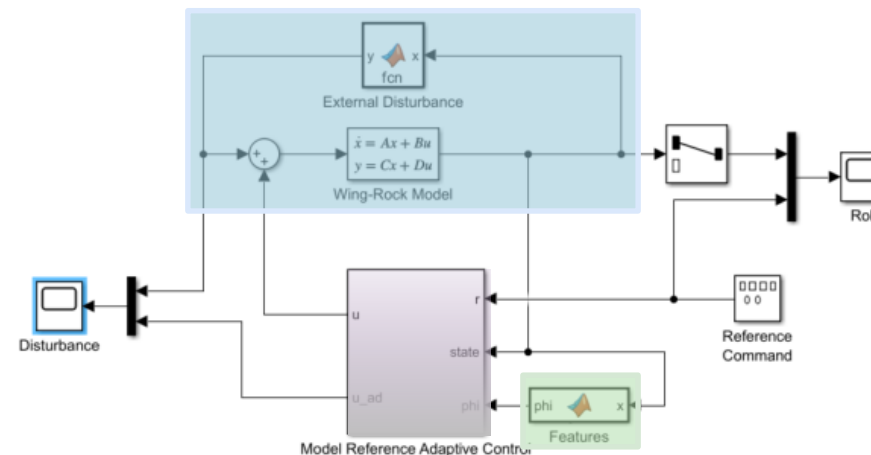
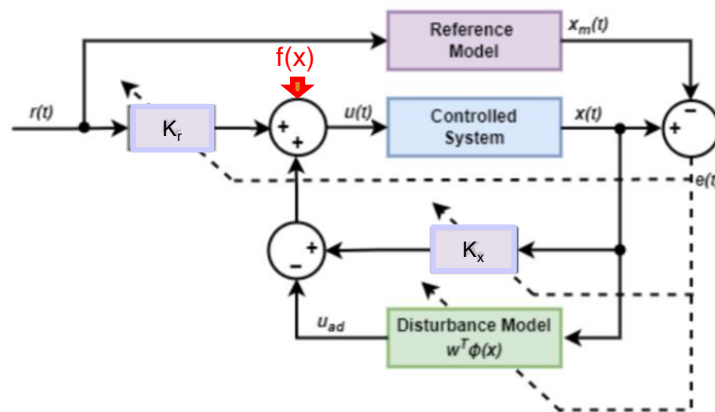

Smarter Control Design – Key Takeaways

There is no single “best” controller

- Start with the best plant model you can build
 - Model quality and correct parameters are essential for design of controls
- Linear control remains the backbone
 - Transparent, robust, and fast to design
 - Highly effective around known operating points.
- Gain scheduling addresses known nonlinearity
 - Handles expected operating variations with smooth transitions between regimes.
- Model Predictive Control enables optimal control under constraints
 - Well suited for MIMO systems, constraints, and optimization-based control.
- Adaptive control handles the unexpected
 - Addresses unknown or changing dynamics due to aging, disturbances, or plant variation